

LIMPAR®



Ersatzteilliste

Spaltenschieber

SP94 ab Maschinen-Nr.: FPH-H5

4F Maschinentechnik GmbH / Am Gasspeicher 6 / 49453 Rehden
Tel: 05446 / 99 70 40, Fax: 05446 / 99 70 42, E-Mail: info@4-f.de

www.limpar.de

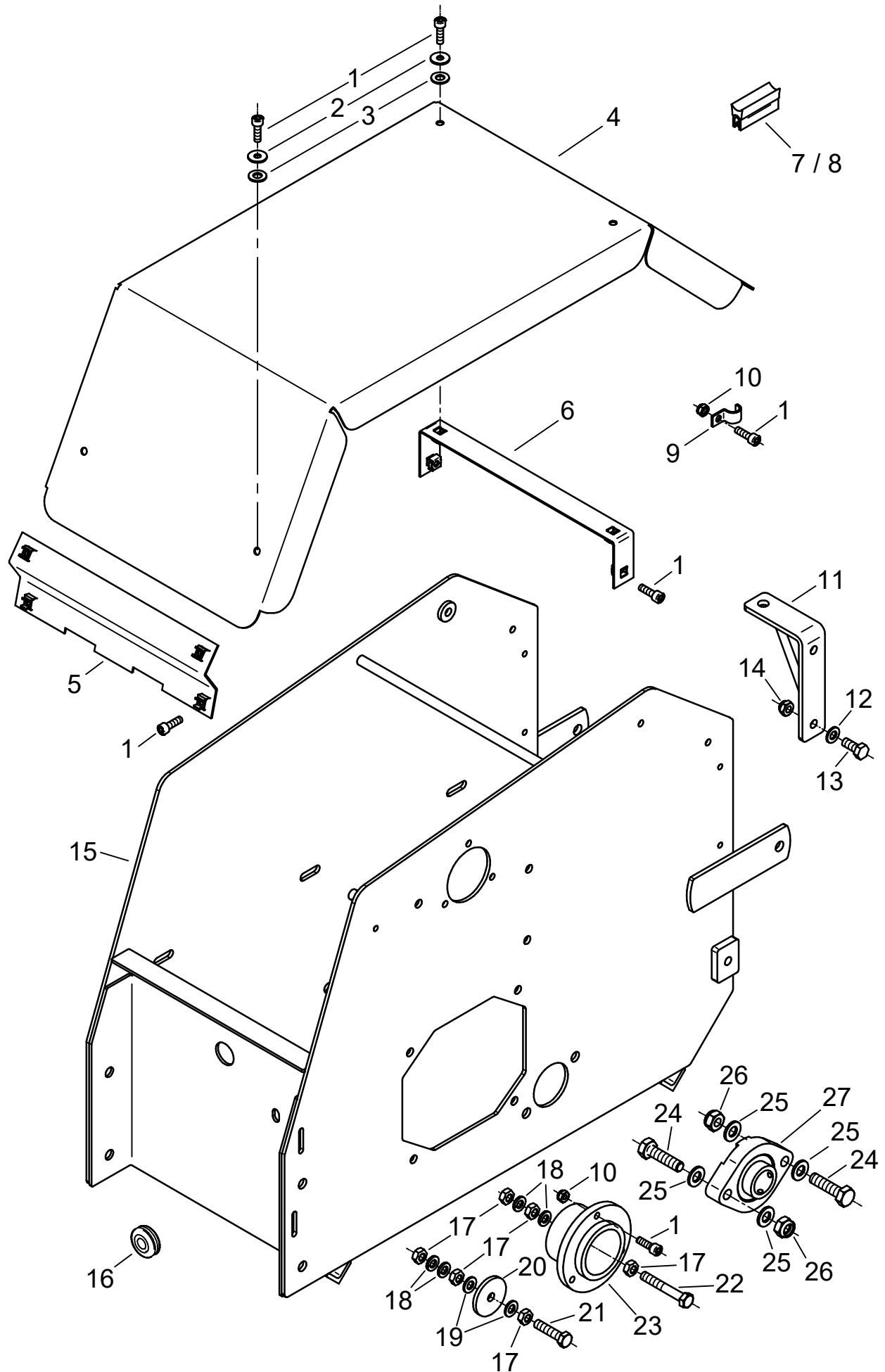

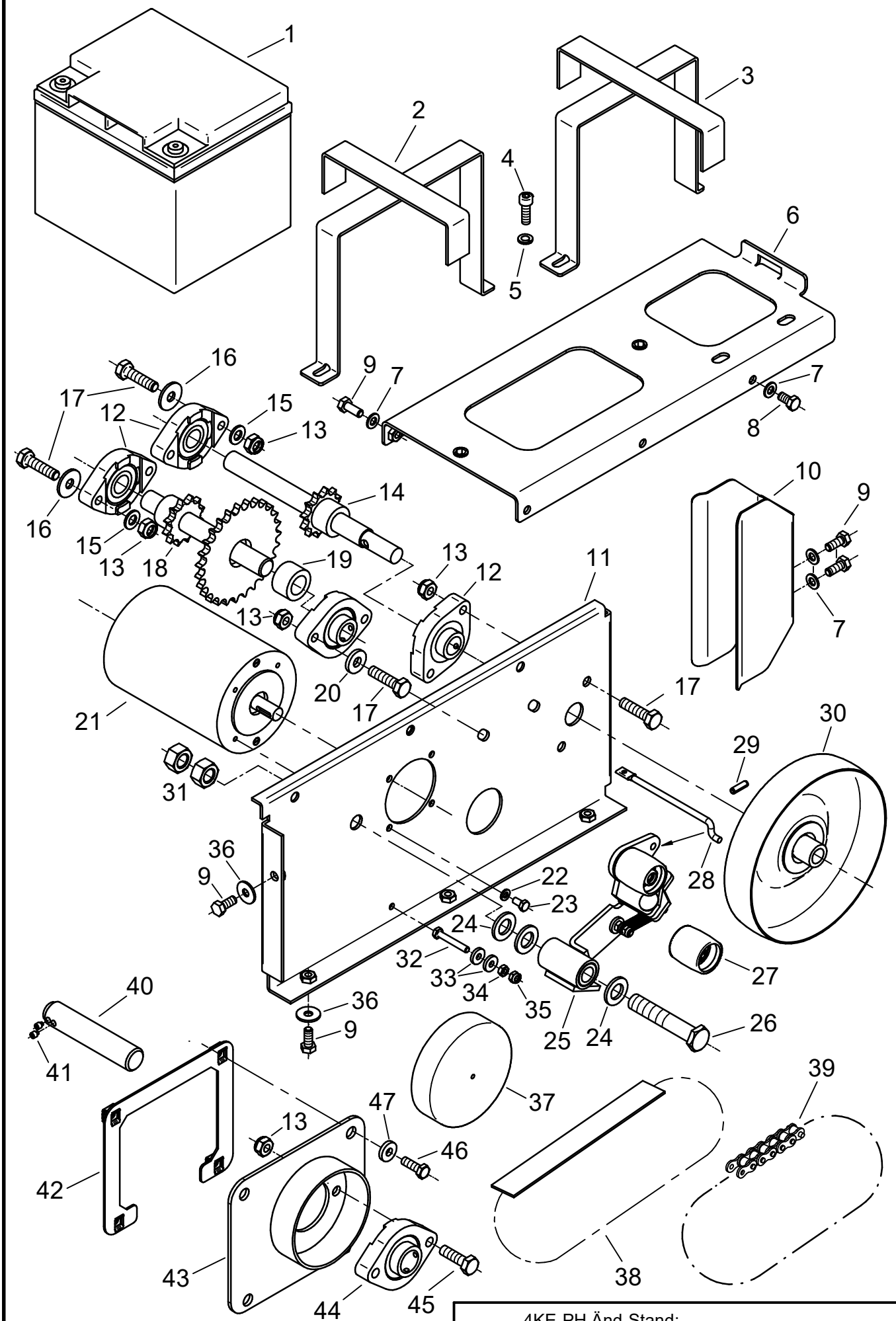

Pos.	Artikel-Nr.	Bezeichnung	Pos.	Artikel-Nr.	Bezeichnung
1	4KO-B09	AGM-Batterie 12/50	38	4HC-A01	Flachriemen
2	FPH-110 Z	Batteriebügel vorn	39	4HD-F361	Kette
3	FPH-111 Z	Batteriebügel hinten	40	4DC-K21	Fl.-Welle Sps
4	4HO-G15 Z	Innen-6kt-Schr. M8x25	41	4KC-A96	Gewindestift
5	4HW-F08 Z	Federring M8	42	FPH-220	Mutterblech Sp4
6	FPH-119	Batterieplatte Sp94-3	43	FPH-122 Z	Lagerdeckel Sp4
7	4HW-A08 Z	Scheibe Ø8,3	44	4KC-A93	Guß-Flanschlager 25
8	4HO-A13 Z	6kt.-Schraube M8x16	45	4HO-A26 Z	6kt.-Schraube M10x35
9	4HO-A14 Z	6kt.-Schraube M8x20	46	4HO-A15 V	6kt.-Schraube M8x25
10	FPH-121	FL-Führung SpS3	47	4HW-D08 Z	Scheibe, dick Ø8,4
11	FPH-103 Z	Tragwand Sp31			
12	4KC-B67	Flanschlager EBS-20			
13	4HR-C10 Z	Stoppmutter M10			
14	FPH-107 Z	Fl-K-Welle Sp3			
15	4HW-A10 Z	Scheibe Ø10,5			
16	4HW-B10 Z	Scheibe, groß Ø10,5			
17	4HO-A27 Z	6kt.-Schraube M10x40			
18	FPH-106 Z	Zwischenwelle Sp3			
19	4DJ-E07 Z	Distanzstück S3			
20	4HW-D10 Z	Scheibe, dick Ø10,5			
21	FPH-209	E-Motor m. Anschlüsse			
22	4HW-F06 Z	Federring M6			
23	4HO-A07 Z	6kt.-Schraube M6x12			
24	4HW-A16 Z	Scheibe Ø17			
25	FPH-204	Mont. Fl.-Spanner 3			
26	4KC-B112	Spannerachse			
27	4KC-A82	Tonnenrolle 10			
28	4DC-C25 Z	Zugstange Sp3			
29	4HX-G25	Spannhülse Ø6x15			
30	FBB-105 Z	Flachriemenscheibe			
31	4HR-A16 Z	Mutter M16			
32	4HO-A42 Z	6kt.-Schraube M6x50			
33	4HW-D06 Z	Scheibe, dick Ø6,3			
34	4HR-A06 Z	Mutter M6			
35	4HR-C06 Z	Stoppmutter M6			
36	4HW-B06 Z	Scheibe, groß Ø6,3			
37	4HJ-G11	Kappe	4KE-PH Änd-Stand: -		

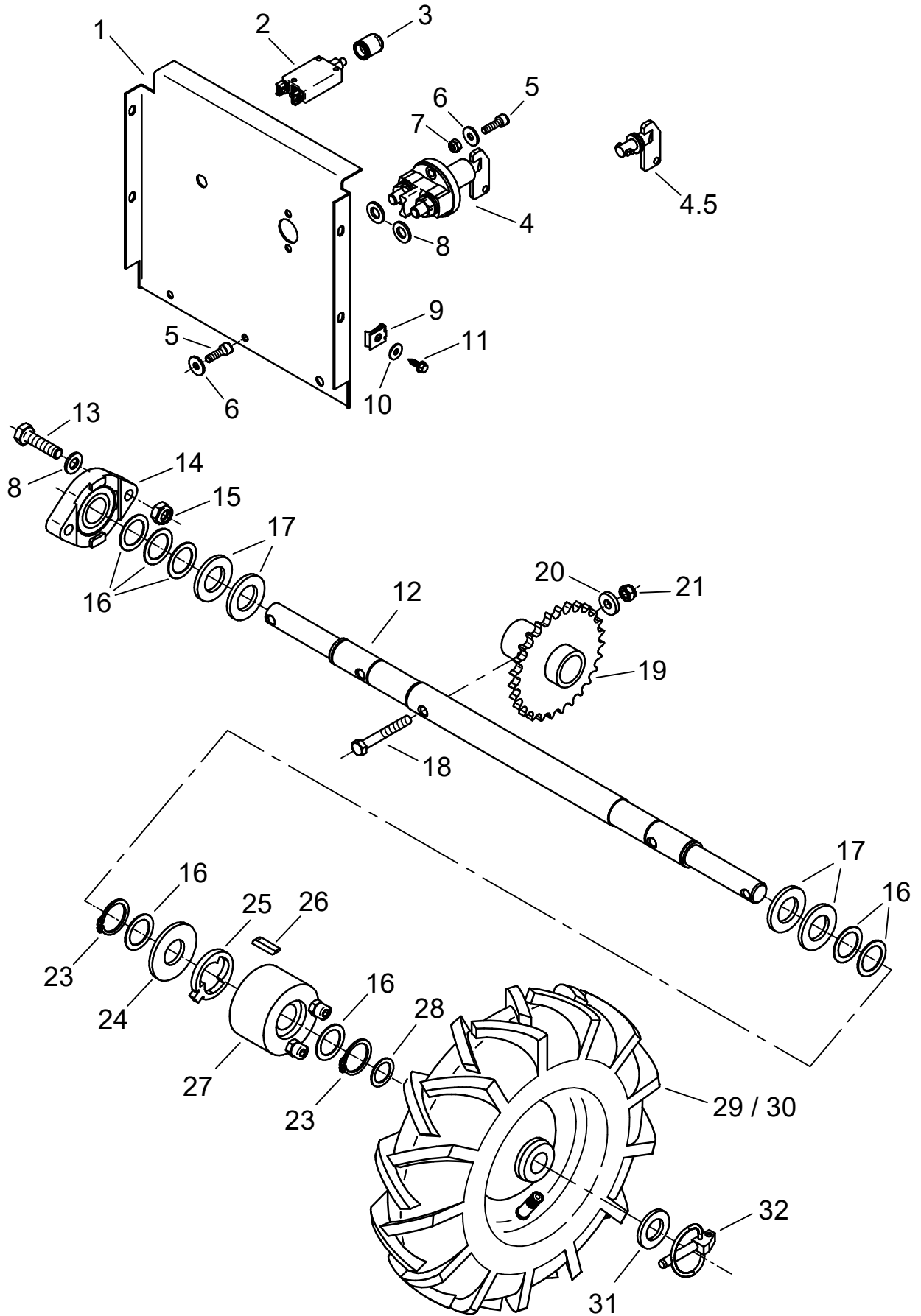

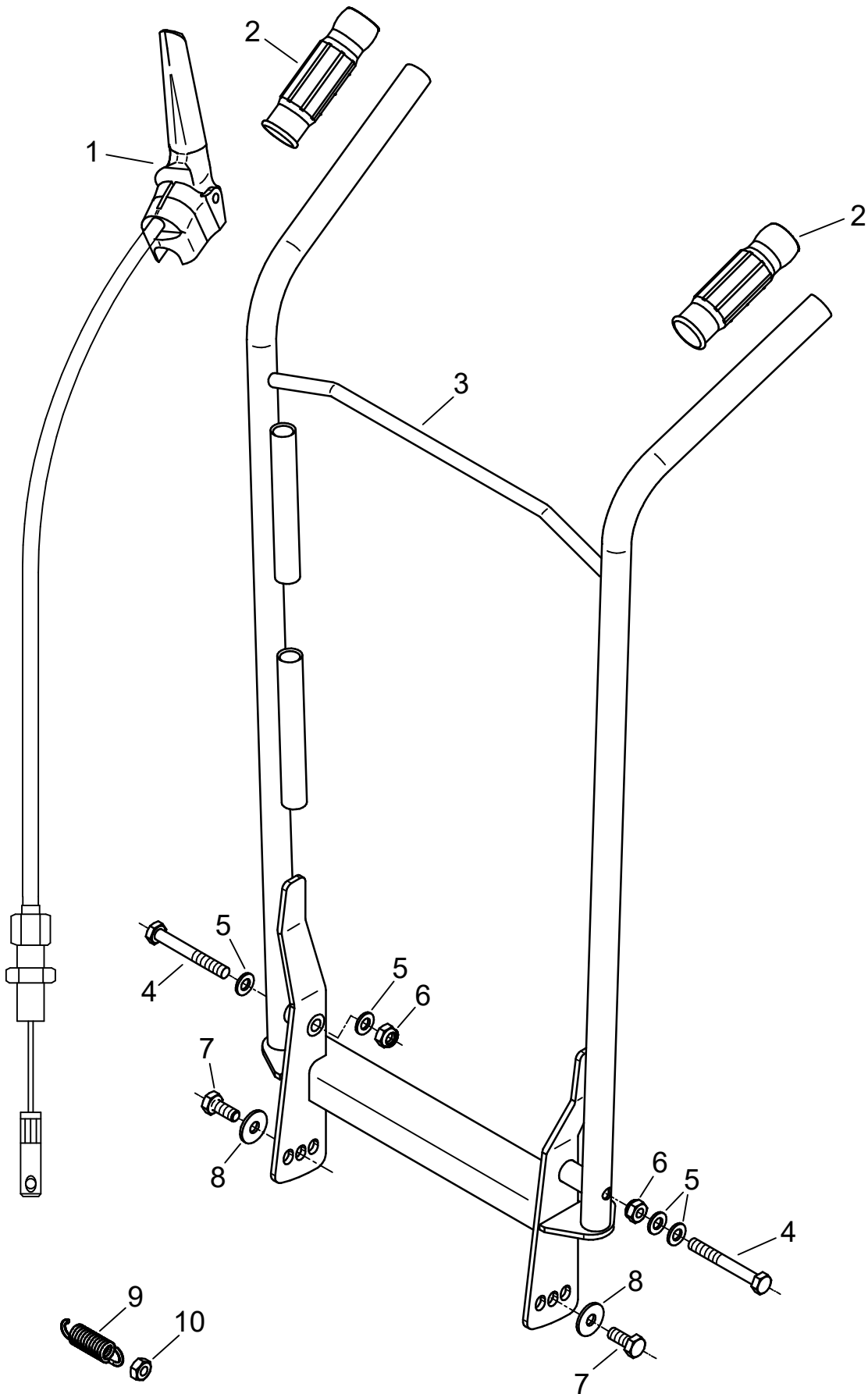

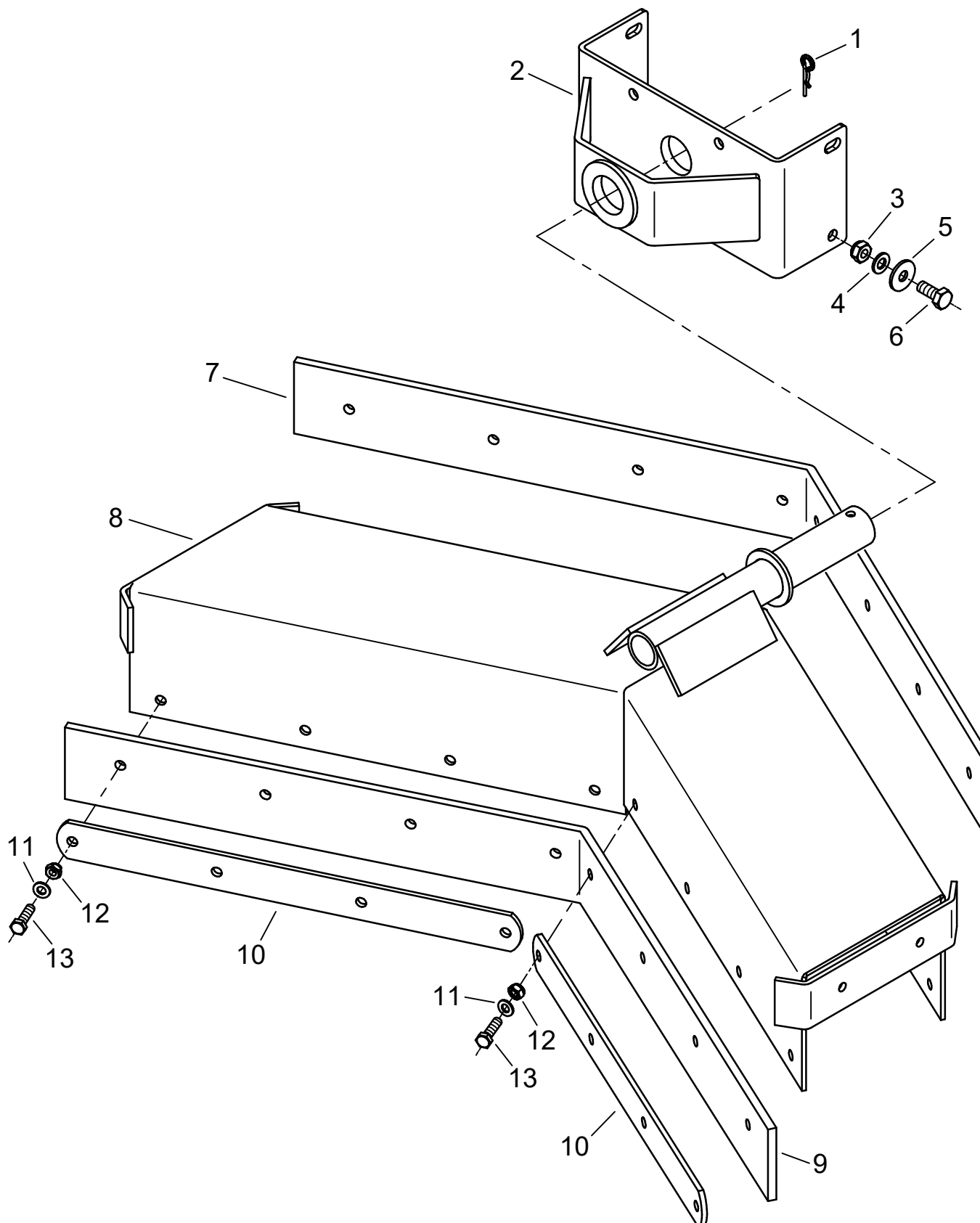

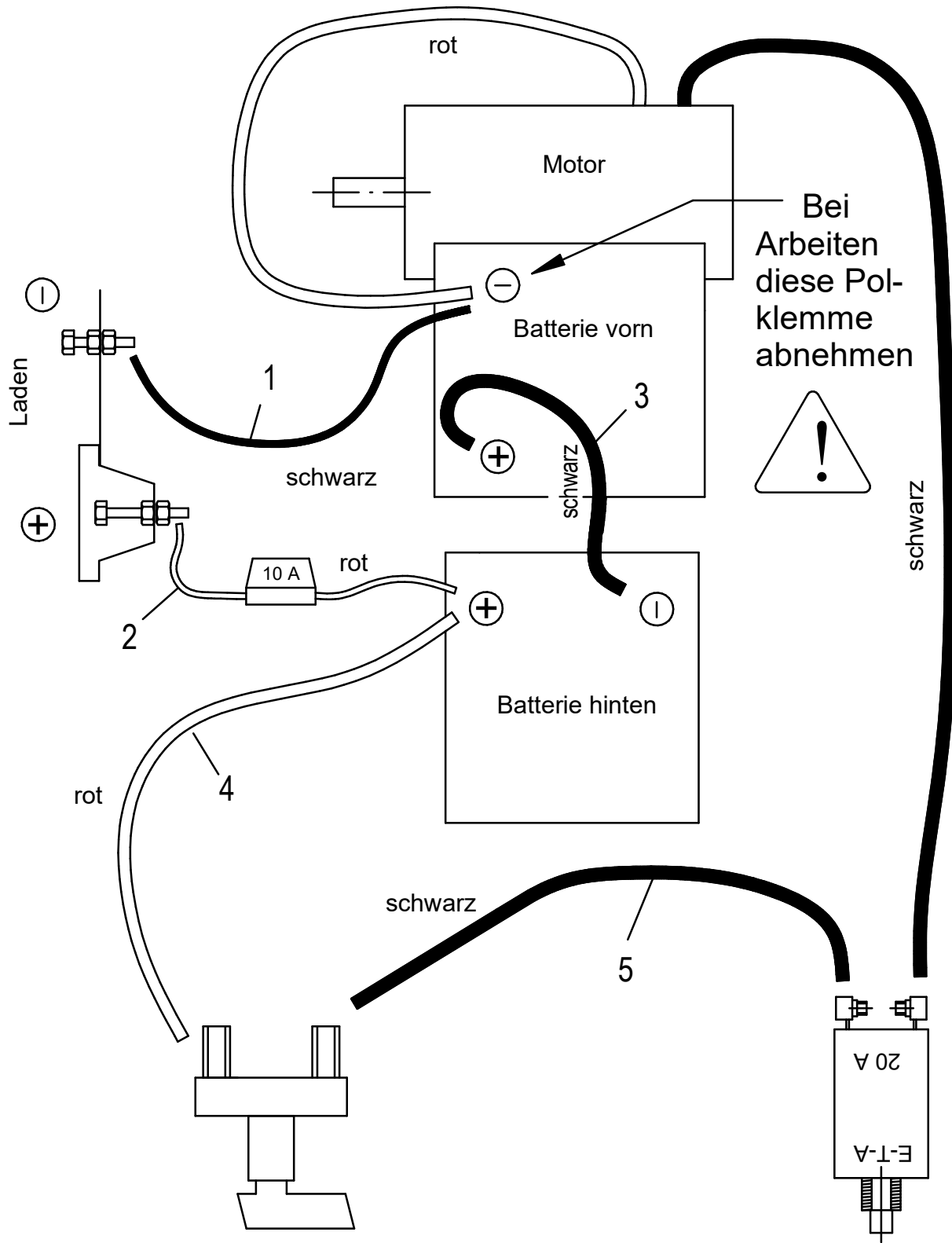

vereinfachte Darstellung



